

INLET/OUTLET CONNECTIONS:

- OPTION 1: 3" MALE CAM LOCK QUICK CONNECT
- OPTION 2: 3" FEMALE CAM LOCK X 2" MALE CAM LOCK REDUCING QUICK CONNECT ATTACHED TO OPTION 1
- OPTION 3: REMOVE VALVE ENDS, REPLACE WITH VALVE ENDS WITH 2" MALE CAM LOCK QUICK CONNECTS INSTALLED

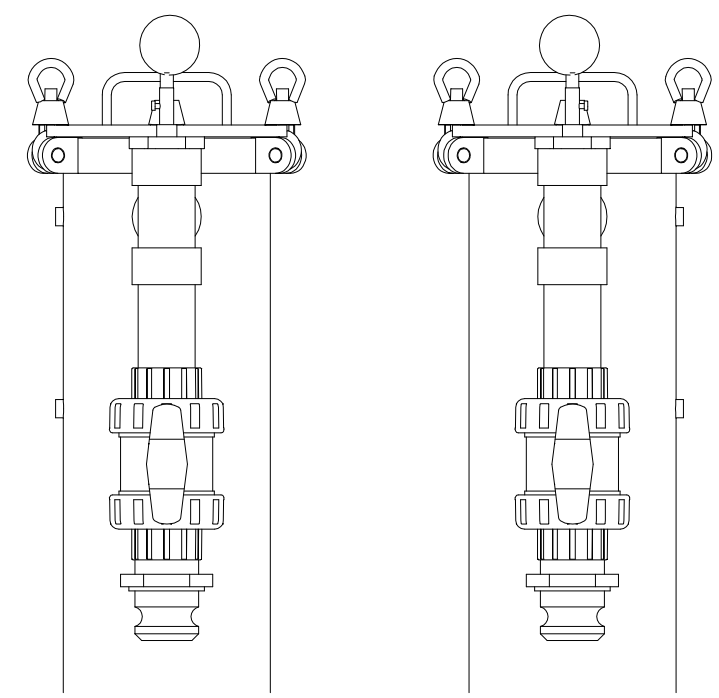

CONNECTION OPTION 3

DRAWN CH	DATE 12/7/09	CUSTOMER	ENCOTECH RL 519 Eighty Four, PA 724-222-3334 Fx 724-222-4090		
CHECKED		JOB			
APPROVED		CUSTOMER PO	BAG FILTERS SKID		
SCALE 1.5"=1'		FILE NAME			
<small>THIS DRAWING, INCLUDING THE INFORMATION, DATA, AND DESIGN IS THE PROPERTY OF ENCOTECH, INC. THE DESIGN CONCEPTS AND INFORMATION CONTAINED HEREIN ARE PROPRIETARY TO ENCOTECH, INC., AND ARE SUBMITTED IN CONFIDENCE. THEY MUST NOT BE DISCLOSED, REPRODUCED, OR OTHERWISE USED IN ANY MANNER DETRIMENTAL TO THE INTERESTS OF ENCOTECH, INC.</small>			DRAWING NO. 14170-120	SHEET 1 OF 1	REV. 02